CUNY conference on the word in phonology

Thursday 14 January 2010

Word-final patterns in Japanese: a mono-stratal approach

Kuniya NASUKAWA

Tohoku Gakuin University, Sendai, Japan

Introduction

■ Issue: representations

- What kind of representation is most appropriate for recent **mono-stratal** approaches to phonological derivation?
- Focus on **morpheme-final regularities** in Japanese and attempt to identify suitable representations for verb stems.

Introduction

■ Roadmap

- The static distributions of word-final/morpheme-final segments at the two levels in relation to the CV dichotomy in Japanese.
- The disparity between two static patterns within a mono-stratal model of phonological derivation
- A representation of prosodic structures to account for the word-final/morpheme-final static distribution.
- An analysis of Japanese verb inflection by adopting a licensing/government-based theory of prosodic representation

Static regularities

■ Word-final patterns in Japanese

(1) a. Nouns

sakana 'fish'

tamago 'egg'

tegami 'letter'

kaze 'wind'

b. Adjectives (*i* = adjectival suffix)

ooki-i 'big'

taka-i 'high'

too-i 'far'

samui-i 'chilly'

c. Case markers

-*ga* nominative

-*o* accusative

-*ni* dative

-*no* genitive

d. Postpositions

de 'at' (e.g. *uti-de* 'at home')

e 'to' (e.g. *gakkoo-e* 'to school')

to 'with' (e.g. *tomodati-to* 'with a friend')

kara 'from' (e.g. *yama-kara* 'from mountain')

e. Nouns with a final *n*

hon 'book'

ten 'dot, spot'

Static regularities

■ Verb-stem-final static patterns in Japanese

(2) a. Vowel-ending

stem	non-past (- <i>ru</i>)	negative (- <i>nai</i>)
<i>mi</i> - 'watch, see'	<i>mi-ru</i>	<i>mi-nai</i>
<i>tabe</i> - 'eat'	<i>tabe-ru</i>	<i>tabe-nai</i>
<i>su</i> - 'do'	<i>su-ru</i>	<i>si-nai</i>

Static regularities

(2) b. Consonant-ending

stem	non-past (- <i>rw</i>)	negative (- <i>nai</i>)
<i>tas</i> - 'add'	<i>tas-w</i>	<i>tas-anai</i>
<i>sir</i> - 'know'	<i>sir-w</i>	<i>sir-anai</i>
<i>kak</i> - 'write'	<i>kak-w</i>	<i>kak-anai</i>
<i>tog</i> - 'sharpen'	<i>tog-w</i>	<i>tog-anai</i>
<i>jom</i> - 'read'	<i>jom-w</i>	<i>jom-anai</i>
<i>sin</i> - 'die'	<i>sin-w</i>	<i>sin-anai</i>
<i>tob</i> - 'fly'	<i>tob-w</i>	<i>tob-anai</i>
<i>tat</i> - 'stand'	<i>tat-w</i> (> <i>tatsw</i>)	<i>tat-anai</i>
<i>kaw</i> - 'buy'	<i>kaw-w</i> (> <i>kaw</i>)	<i>kaw-anai</i>

Static regularities

- A disparity between the two static patterns

(3)

		... CV]	... VM]	... VC]
a.	Lexical (underived)	✓ (most morphemes)	✓	✓ (only verb stems)
b.	Non-lexical (derived)	✓ (most morphemes)	✓	

Multi-stratal derivation

(4)

a. Underlying phonology ← (3a)



b. Surface phonology } ← (3b)



c. Categorical phonetics }

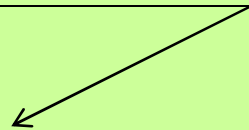

Articulation

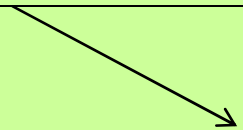

Auditory perception

Mono-stratal approach

(5) Harris (2004)

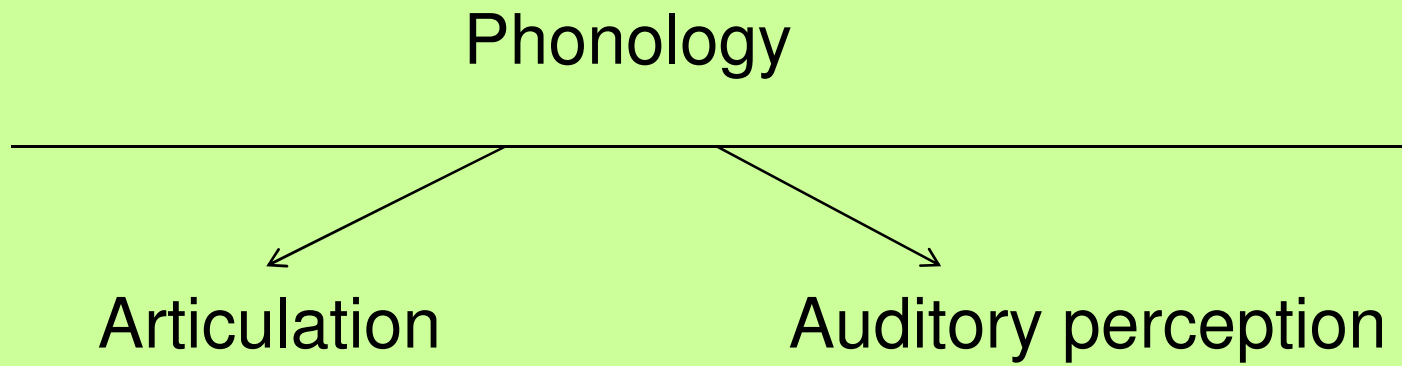

The structure of the domain-final Cs

(6) a. Abe (1987)

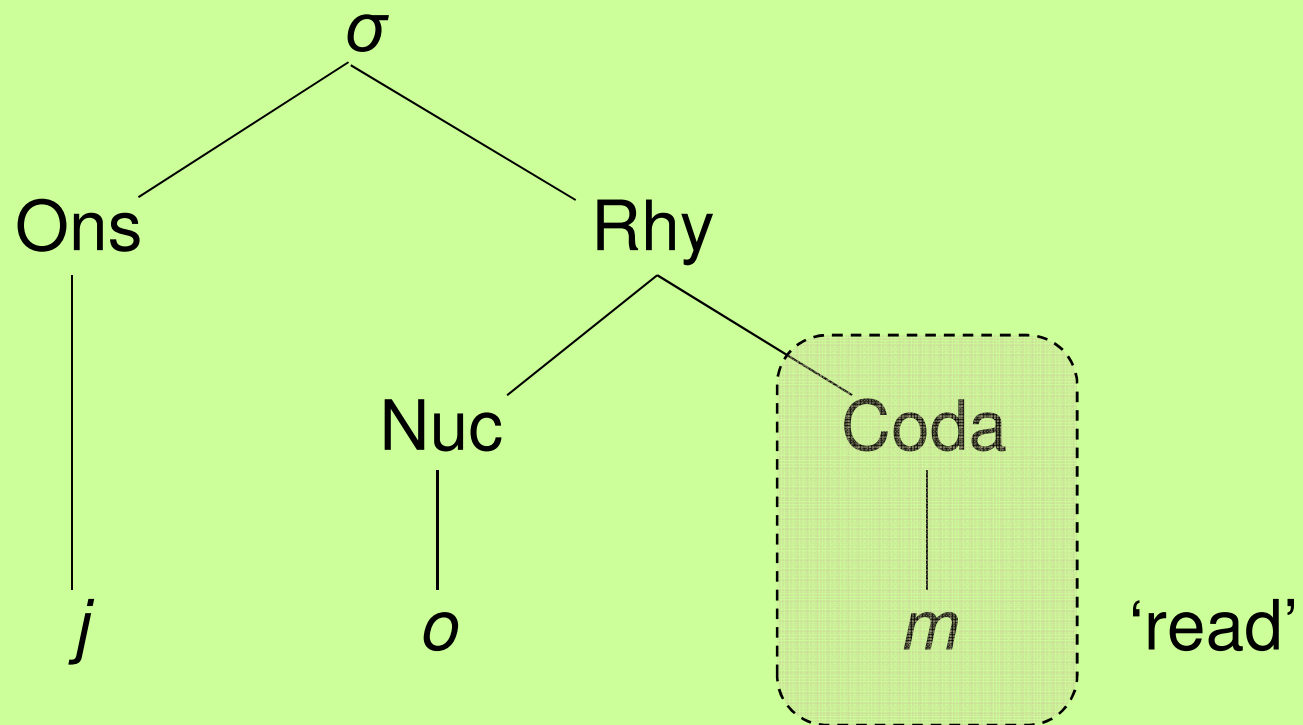

Resyllabification

(6) b. Vance (2008)

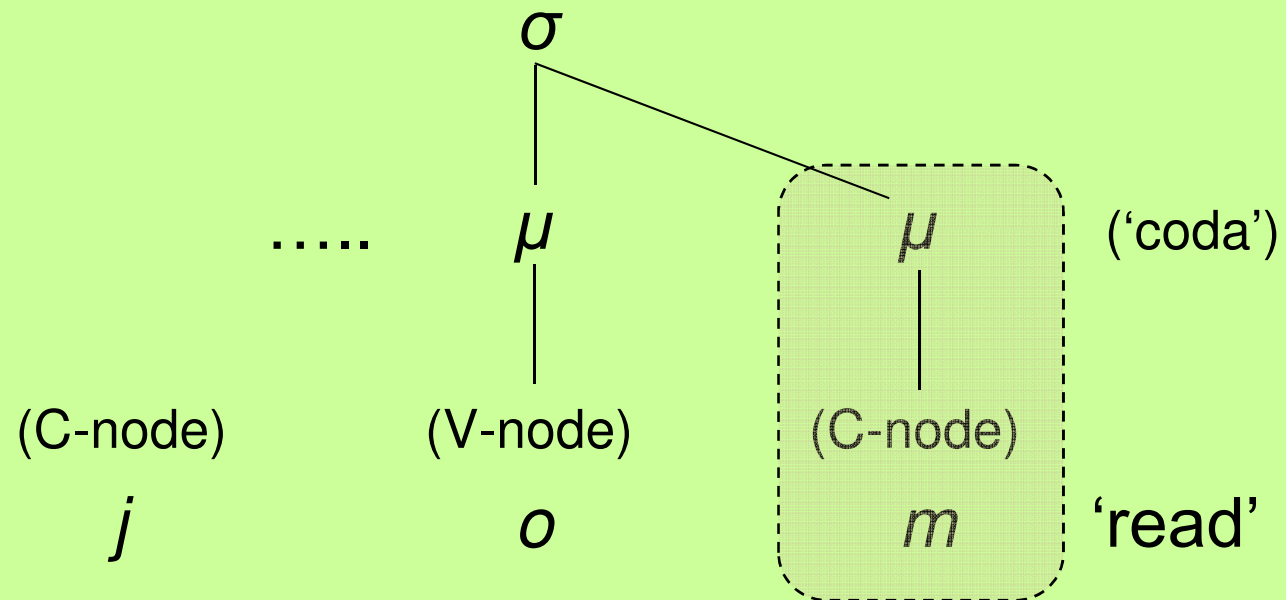

Resyllabification

(7) a. Vance (2008)

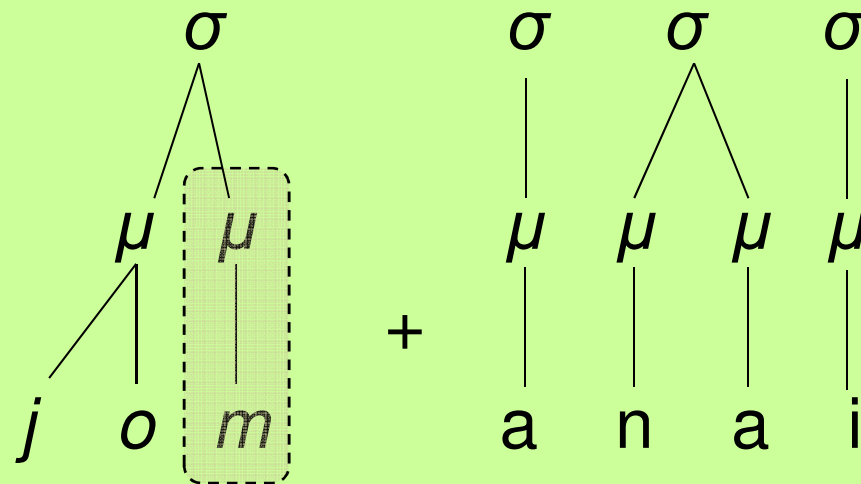

'coda'

Resyllabification

(7) b. Vance (2008)

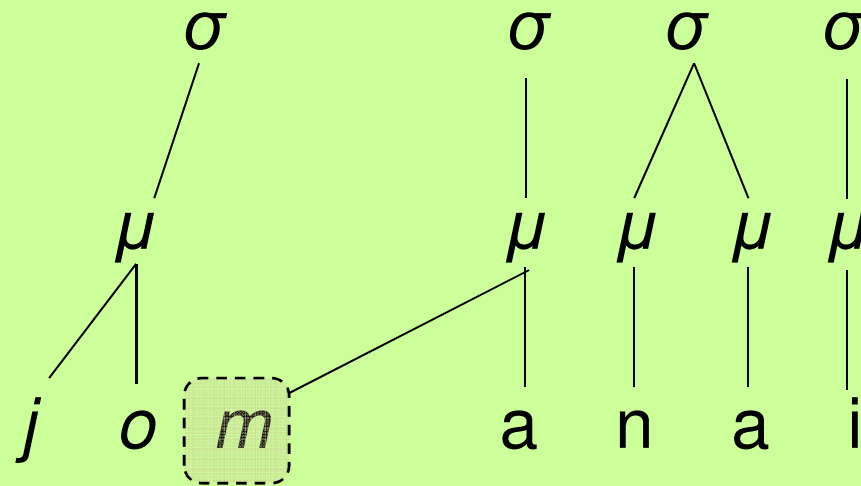

'onset'

Mono-stratal approach

- This kind of structure-changing operation is undesirable in terms of faithfulness to lexical forms.
- Most versions of the licensing/government based framework regard this as failing to conform to the Structure Preservation principle.

(8) **Structure Preservation Principle** (cf. Harris 1994, Backley & Takahashi 1998, Takahashi 2004)

Dependency (licensing) relations holding of lexical representations also hold at the level of interface to outer-facilities.

Verb stem representations

C-final verb stems

(9) *jom* 'to read'

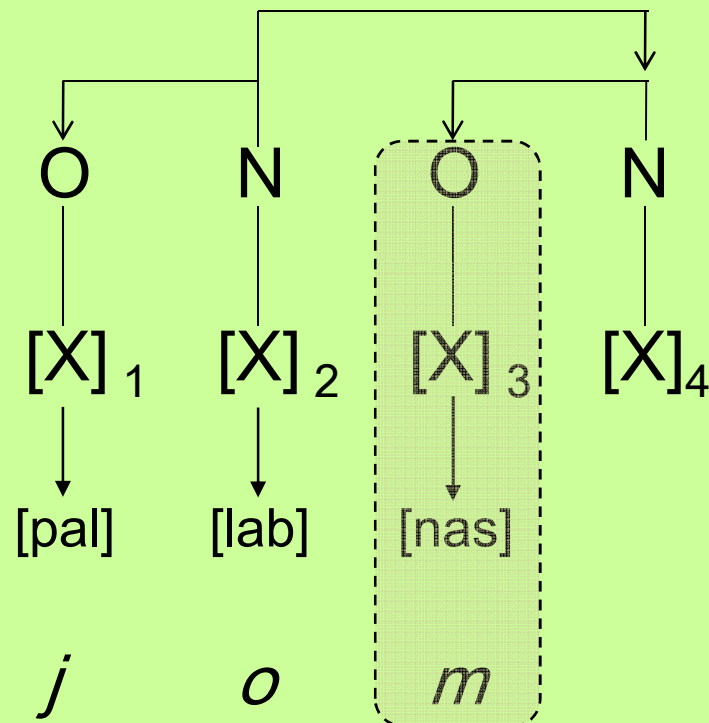

Verb stem representations

(10) **Onset Licensing** (cf. Harris 1994: 160)

An onset must be licensed by a nucleus.

(11) **Domain-final-empty-nucleus parameter**

(Kaye 1990: 314, Harris 1994: 162)

Domain-final nucleus licensed?

Parameter setting	Examples
ON	English, French, Luo,
[OFF]	Desano, Italian, Telugu,

Verb stem representations

(12) *mi.∅∅* 'to read'

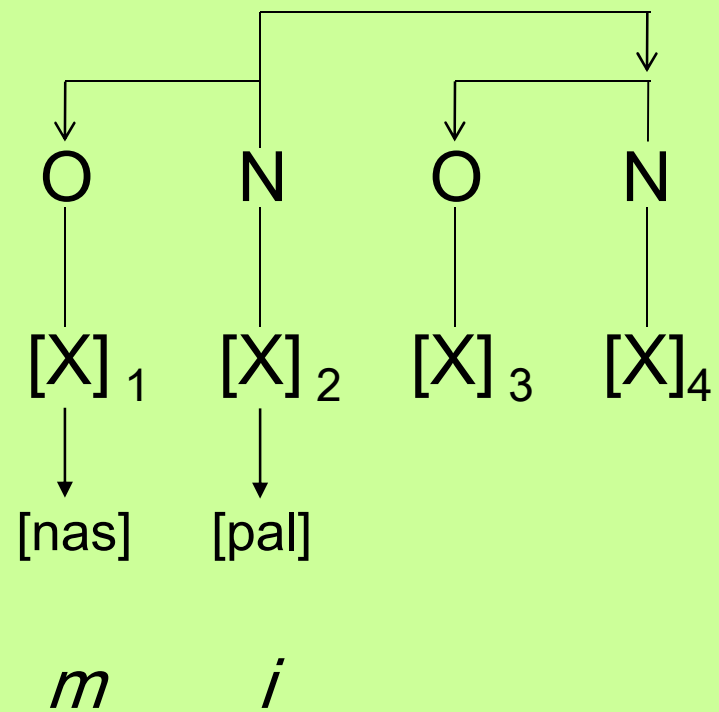

Verb inflection in Japanese

(13) a. Conventional concatenation

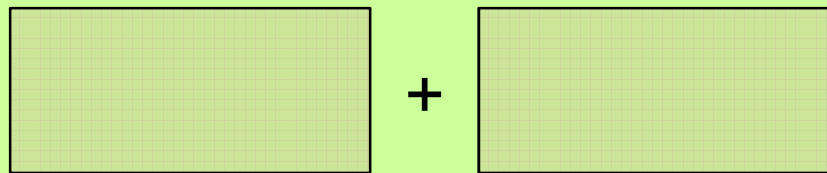

b. Overlapping

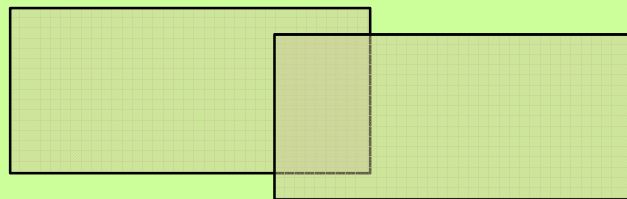

Verb inflection in Japanese

(14)

a. *jo.m*∅

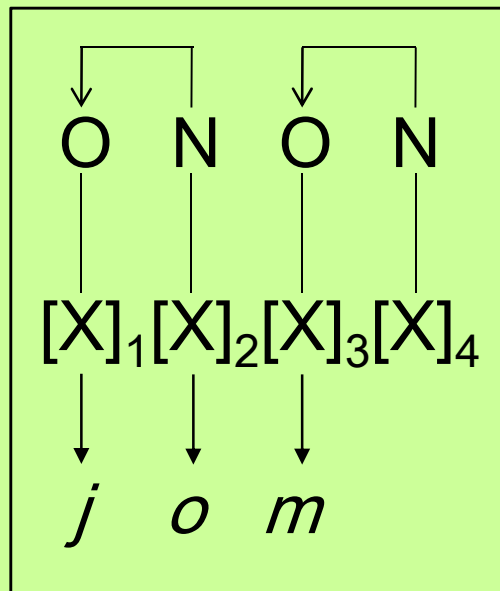

b. -∅*a.na*.∅*i*

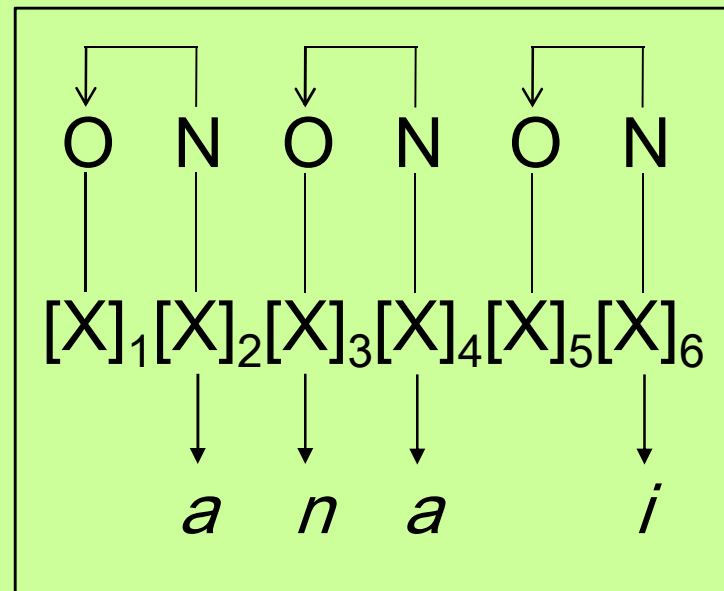

Verb inflection in Japanese

Empty onset

(15) **Condition on the phonetic manifestation of an empty onset**

An empty onset is phonetically silent if it is licensed by a following melodically filled nucleus.

Verb inflection in Japanese

(16) *jo.m*∅ + *-∅a.na.∅i*

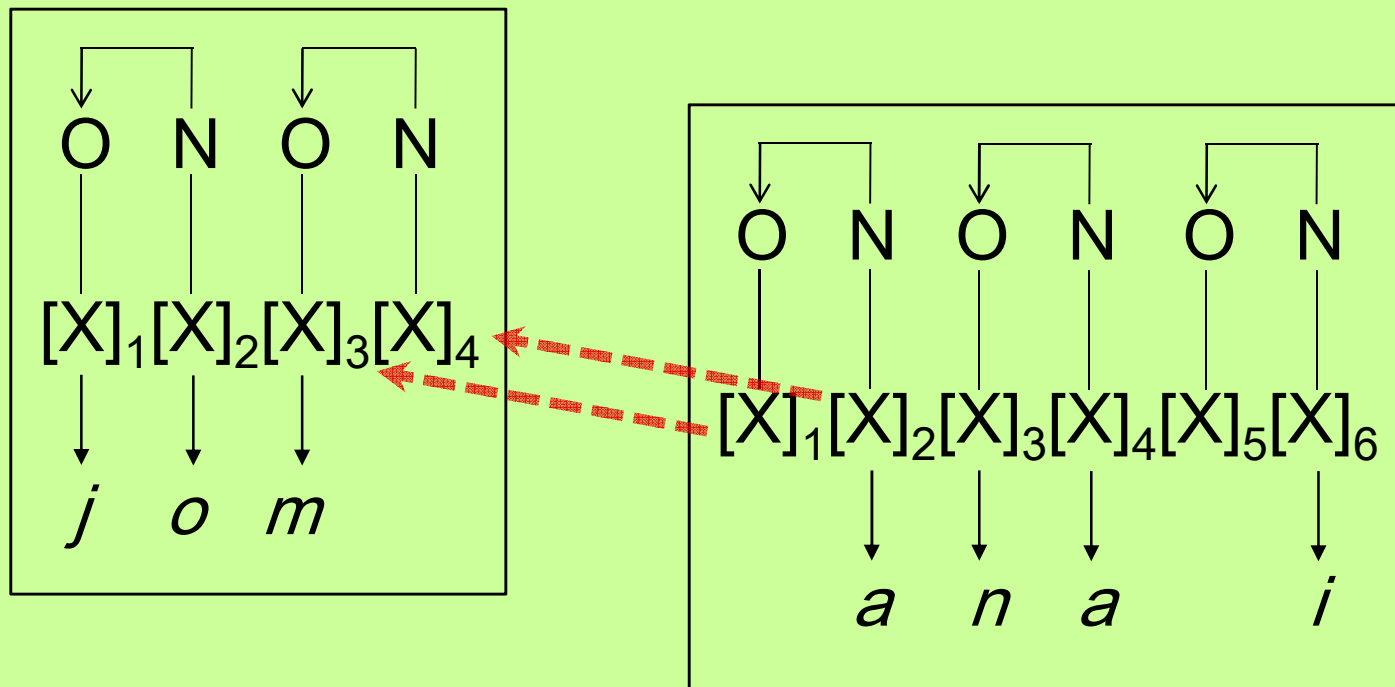

Verb inflection in Japanese

(17) *jo.ma.na.Øi*

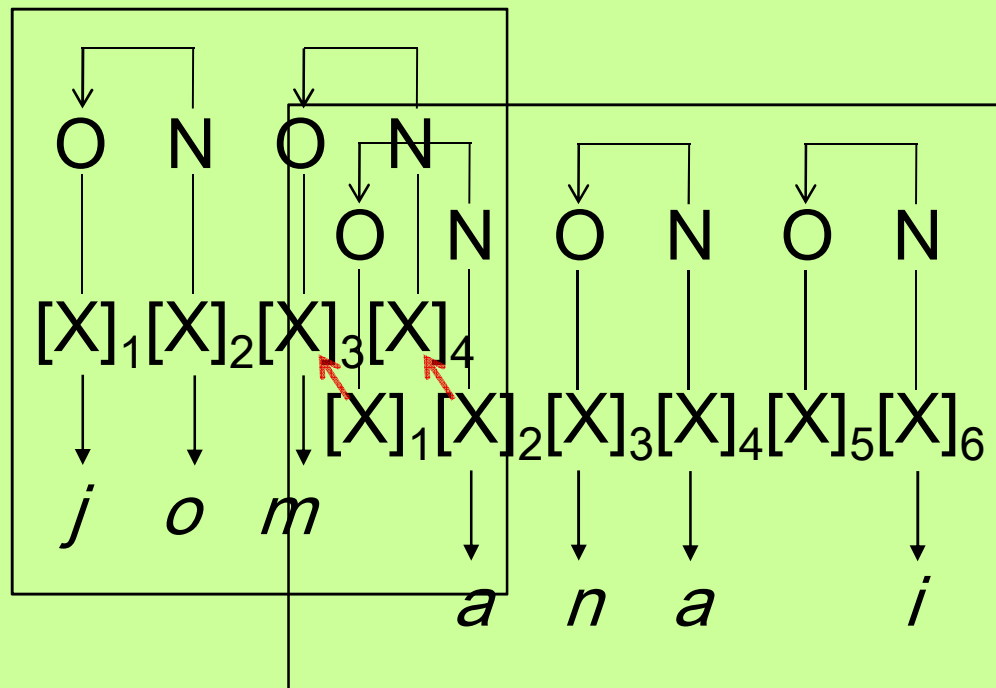

Verb inflection in Japanese

(18) *jo.m∅ + -∅a.na.∅i*

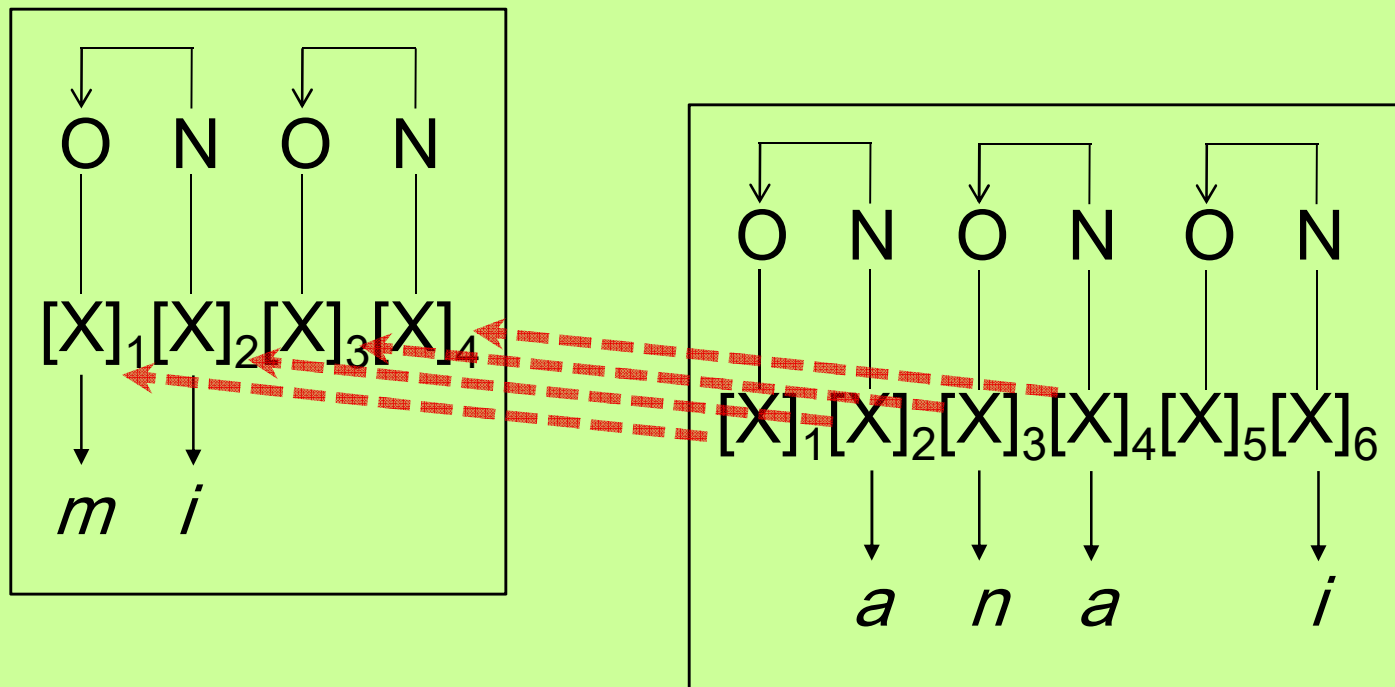

Verb inflection in Japanese

(19) **Avoid melodic emptiness**

Disallow empty categories at boundaries in concatenated forms.

(20) **Max (Morph-Head)**

Parse the melodic material in a morphological head (i.e. verb stem).

Verb inflection in Japanese

(21)

a. **Structure Preservation** (=8)

Dependency relations holding of lexical representations also hold at the level of interface to outer-facilities.

b. **Avoid melodic emptiness** (=19)

Disallow empty categories at boundaries in concatenated forms.

c. **Max (Morph-Head)** (=20)

Parse the melodic material in a morphological head.

Conclusion

- This paper has claimed that the verb stem always ends with a nucleus.
- This analysis unifies the two distinct static patterns into one and also conforms to the Structure Preservation Principle.
- With the proposed representations, the verb inflection is treated as an overlapping process between a verb stem and a suffix, rather than as a conventional concatenation.
- This operation is attributed to the interaction among the principles in (21).

Appendix: the structure of the placeless nasal N

- N consists of a two-position sequence: **an onset and a nucleus**.
 - Onset → consonantal; Nucleus → vocalic/syllabic
 - [nasal] and [stop] in the onset → **realised as a placeless nasal stop**

(22)

a. 'Moraic' placeless nasal

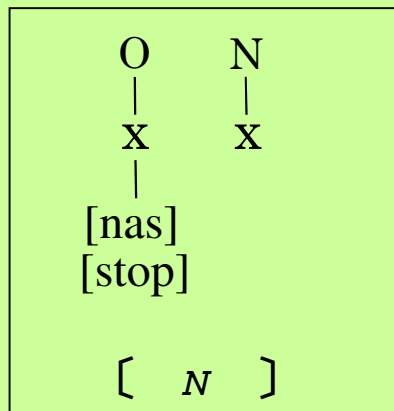

b. Alveolar nasal

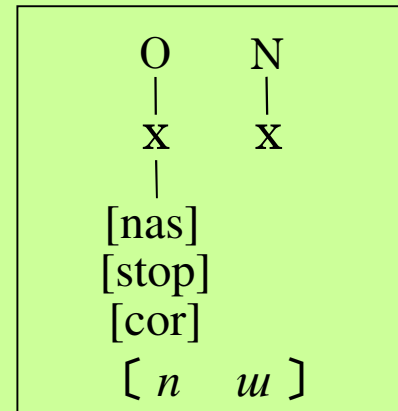

Phonetic interpretation

References (1)

- Backley, Phillip & Toyomi Takahashi (1998). Element activation. In Eugeniusz Cyran (ed), *Structure and interpretation – studies in phonology*, Lublin: Folium, 13-40.
- Abe, Yasuaki (1987). Metrical structure and compounds in Japanese. In Takashi Imai & Mamoru Saito (eds.), *Issues in Japanese linguistics*, Dordrecht: Foris, 5-52.
- Backley, Phillip & Toyomi Takahashi (1998). Element activation. In Eugeniusz Cyran (ed.), *Structure and interpretation — studies in phonology*, Lublin: Folium, 13-40.
- Harris, John (1994). *English sound structure*, Oxford: Blackwell.
- Harris, John (1997). Licensing Inheritance: an integrated theory of neutralisation, *Phonology* 14, 315-370.
- Harris, John (2004). Release the captive coda: the foot as a domain of phonetic interpretation. In John Local, Richard Ogden & Rosalind A. M. Temple (eds.), *Phonetic interpretation: Papers in Laboratory Phonology* 6, Cambridge: Cambridge University Press, 103-129.
- Harris, John & Geoff Lindsey (1995). In Jacques Durand & Francis Katamba (eds.), *Frontiers of phonology: atoms, structures, derivations*, Harlow, Essex: Longman, 34-79.
- Kaye, Jonathan D. (1990). 'Coda' licensing, *Phonology* 7, 301-330.
- Kaye, Jonathan D. (1995). Derivations and interfaces. In Jacques Durand & Francis Katamba (eds.), *Frontiers of phonology: atoms, structures, derivations*, Harlow, Essex: Longman, 289-332.
- Kaye, Jonathan D., Jean Lowenstamm & Jean-Roger Vergnaud (1990). Constituent structure and government in phonology. *Phonology* 7, 193-232.
- McCarthy, John J. & Alan S. Prince (1995). Faithfulness and reduplicative identity. In Jill N. Beckman, Suzanne C. Urbanczyk & Laura Walsh Dickey (eds.), *University of Massachusetts Occasional Papers in Linguistics* 18: *Papers in Optimality Theory*. Amherst: GLSA, 249-384.
- Nasukawa, Kuniya (1998). Prosodic integrity and melodic representation in nasals. *Interdisciplinary Information Sciences* Vol. 4 No. 1, Tohoku University, 1-8.

References (2)

- Nasukawa, Kuniya (2004). Word-final consonants: arguments against a coda analysis. *Proceedings of the Tohoku English Literary Society*, 47-53.
- Nasukawa, Kuniya (2005). *A unified approach to nasality and voicing*, Berlin/New York: Mouton de Gruyter.
- Nasukawa, Kuniya (2007). Relational properties in phonology: precedence and dependency. Paper presented at the CUNY Conference on Precedence Relations.
- Nasukawa, Kuniya (to appear). Prosodic affiliation of NC sequences in Lungu (Cilungu). In Karsten Legère (ed.), *Proceedings of the International Conference on Bantu Languages: Analysis, Description and Theory*, Köln: Rüdiger Köppe Verlag.
- Prince, Alan S. & Paul Smolensky (2004). *Optimality Theory: constraint interaction in generative grammar*, Oxford: Blackwell.
- Scobbie, James, John Coleman & Steven Bird (1996). Key aspects of declarative phonology. In Jacques Durand & B Laks (eds.), *Current trends in phonology: models and methods*, 2 vols. Salford: ESRI.
- Shibatani, Masayoshi (1990). *The languages of Japan*, Cambridge: Cambridge University Press.
- Takahashi, Toyomi (2004). Syllable theory without syllables. Ph.D. dissertation, University College London.
- Tsujimura, Natsuko (1996). *An introduction to Japanese linguistics*, Oxford: Blackwell.
- Vance, Timothy J. (2008). *The sounds of Japanese*, Cambridge: Cambridge University Press.
- Yoshida, Shohei (1990). The 'mora' in Japanese. *Phonology* 7, 331-351.
- Yoshida, Shohei (2003). The syllabic nasal in Japanese. In Stefan Ploch (ed.), *Living on the edge: 28 papers in honour of Johnathan Kaye*, Berlin/New York: Mouton de Gruyter, 527-542.